

CONTENEUR 240 SL  
VERSION DIN

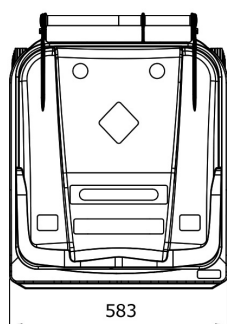
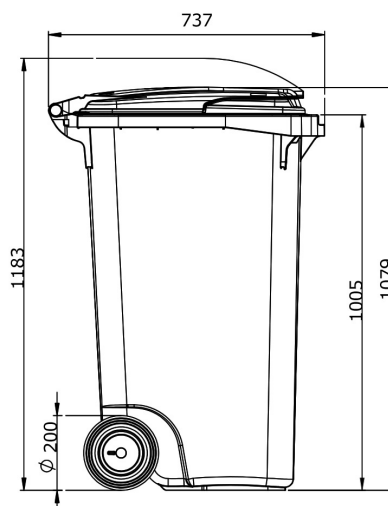
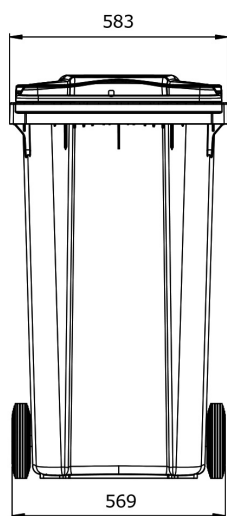

DONNÉES TECHNIQUES

Volume (L):	240,00
Poids à vide environ (kg):	13,00
Masse totale maximal autorisée (kg):	110,00
Matériel:	PEHD, résistant aux UV
Roues:	2 roues Ø 200 mm axe traité anti-corrosion
Couvercle / Conteneur:	2 clips couvercle standard poignée continue ~ Ø 27 mm passage de pied en standard
La Certification:	EN 840, RAL GZ 951/1

OPTIONS

- Différents types de serrures
- Ouvertures couvercles
- Capots
- Encart de sécurité / Encart de CD
- Marquages / Identification
- Variantes de clips
- Différentes tailles de roues en option
- Réduction du bruit
- Biomodules
- Équipement spécial / Accessoires

## Options

### Différents types de serrures



Serrure à gravité 2/4R



Dispositif de verrouillage pour cadenas



Serrure à clé triangulaire 2/4R

### Ouvertures couvercles



Opercule emballages  
155x255 2R CL SL



Surcouvercle  
rectangulaire 2R



Opercule verre 152 2R  
CL SL



Opercule verre 152  
élastomère 2R CL SL



Opercule verre 220  
élastomère 2R CL SL



Petit surcouvercle  
ronde 2R

### Capots



Capot pour le papier  
2R

# CONTENEUR 240 SL VERSION DIN

## Encart de sécurité / Encart de CD



Opercule pour CD 2R



Fente de sécurité 2R

## Marquages / Identification



Marquages individuels  
2/4R



RFID Transponder  
2/4R

## Variantes de clips



Plaque pour  
pictogrammes

## Différentes tailles de roues en option



Roues 250 mm



# CONTENEUR 240 SL VERSION DIN

## Réduction du bruit



## Biomodules



## Équipement spécial / Accessoires

